

# MEGA LITE

## *Ribbon* C O L O R 2 4 V



## USER MANUAL

### Table of Contents

Safety Information.....	3
Specifications.....	4
Main Power Connection.....	6
DMX-512 Connection.....	6
Installation.....	7
Rigging the Fixture.....	8
Main Control Menu.....	9
DMX Profile.....	10
Cleaning & Maintenance.....	11



Check that the unit has not been damaged during transport



Read all cautions and warnings  
prior to operation of this  
equipment

#### Protection Against Fire



Fire

1. Maintain a minimum of 1 foot distance from any type of flame.
3. Replace fuse only with the specified type and rating.
4. Do Not install the unit too close to a heat source.
5. Make sure cables are properly secured away from unit movement.
6. Maximum surface operating temperature 80°.

#### Protection Against Fire



Electrical

1. Disconnect power before servicing.
2. For connection to main power supply proceed to page 5.
3. This unit must be earthed. (electronically grounded)
4. Do not expose unit to rain or moisture.

#### Protection Against Mechanical Hazards



Mechanical

1. Use safety chain when hanging unit.
2. Secure the plastic cover when hanging the light on ceiling.
3. Use quality clamps or bolts when positioning unit
4. Do not open unit while it is on, risk of electrical shock.

# Specifications

## 4371-Color Ribbon 24V

### Specifications

IP Rating: IP 67

LED Quantity: 300

Red: 300  
Green: 300  
Blue: 300

LED Type: SMD-Tri Colored  
Voltage: 24V  
Avg rated Life: 30,000hrs  
Operating temperature: -40°C to 80°C  
Fastening System: Mounting Clips (included)  
Led Spacing: .65" / 16.6mm  
Cuttable Every: 3.92" / 100mm

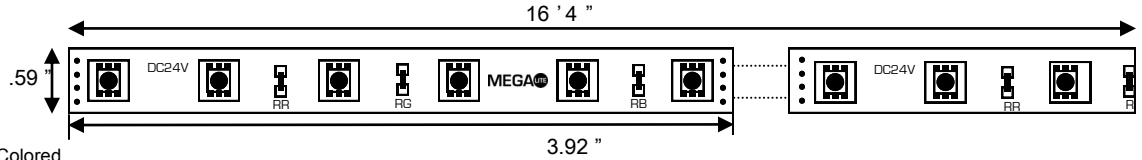

Fixture	Antistatic Bag Packaging
Size: 16'4" / 5 Meters L .59" / 14mm W .24" / 5mm H	Size: 10.5" L 10" W 1" H
Weight: .75 lbs	Weight: .85 lbs

### Fixture

## 4356- Color Ribbon Power Supply

### Mechanical Specifications

DMX Connectors: 3-pin XLR connectors

Power Connection: External power supply bare cable

Fastening System: 2 fixture mounting points

Fixture	Packaged for Shipping
Size: 4.95"L x 2.65"W x 1.65"H	Size: 6"L x 3"W x 3.5"H
Weight: .6 lbs	Weight: 1.4 lbs

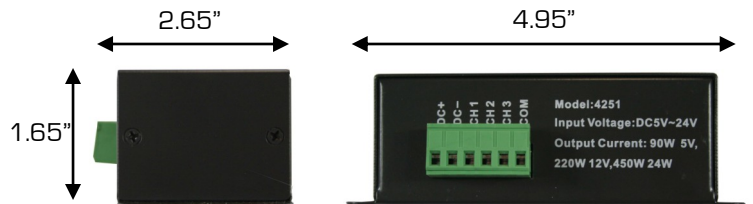

### Electrical Specifications

Input Power: DC5V~DC24V

Output Current: 6A Per channel (total 18A)

Output Power: 5V-90W  
12V-220W  
24V-450W

Brightness Control: 256 Scales

### Control & Programming

Protocol: DMX 512 / 1990

DMX Channels: 3

Control options: Built in functions

## Fixture

### 4357- Color Ribbon Power Extender

## Mechanical Specifications

**Connectors:** Removable phoenix connectors

**Power Connection:** External power supply bare cable

**Fastening System:** 2 fixture mounting points



Fixture	Packaged for Shipping
Size: 4.75"L x 1.56"W x 1.55"H	Size: 6"L x 3"W x 3.5"H
Weight: .4 lbs	Weight: 1.4 lbs

## Electrical Specifications

**Input Power:** DC5V~DC24V

**Output Current:** 6A Per channel (total 18A)

**Output Power:** 5V-90W  
12V-220W  
24V-450W

## Main Power Connection

### Caution!

1. Do not connect fixture to a dimmer system.

The occupation of the connection-cable is as follows coming out of the AC to DC adapter

110V Connection

Cable (USA)	Cable (EU)	Pin
Red	Red	DC +
Black	Black	DC -

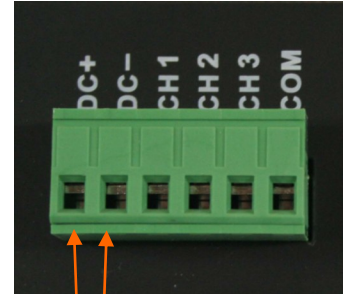

## DMX-512 Connection

The fixture is equipped with 3 pin XLR Sockets for DMX input and output. The sockets are wired in parallel. Only use a shielded twisted pair cable designed for RS-485 and 3 pin XLR plugs and connectors in order to connect the controller with the fixture or the fixture with another.

DMX—input

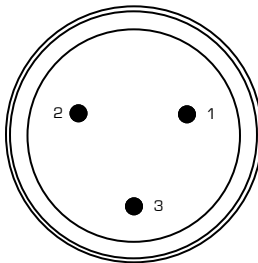

1. Shield
2. Signal (-)
3. Signal (+)

DMX—output

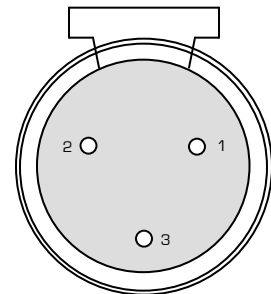

### Caution!

At the last fixture the DMX signal needs to be terminated with a terminator. Solder a 120 Ohm resistor between the (-) and the (+) signal into a 3 pin XLR plug and plug it in to the last fixture on the signal run. Pre-manufactured terminator plugs are available for purchase from your Mega-Lite dealer (HOS-DMXT).

# Installation

## Caution!

1. Each Color Ribbon power supply will only power up to 16.4" of Color Ribbon

## Installing using Color Ribbon Power Supply

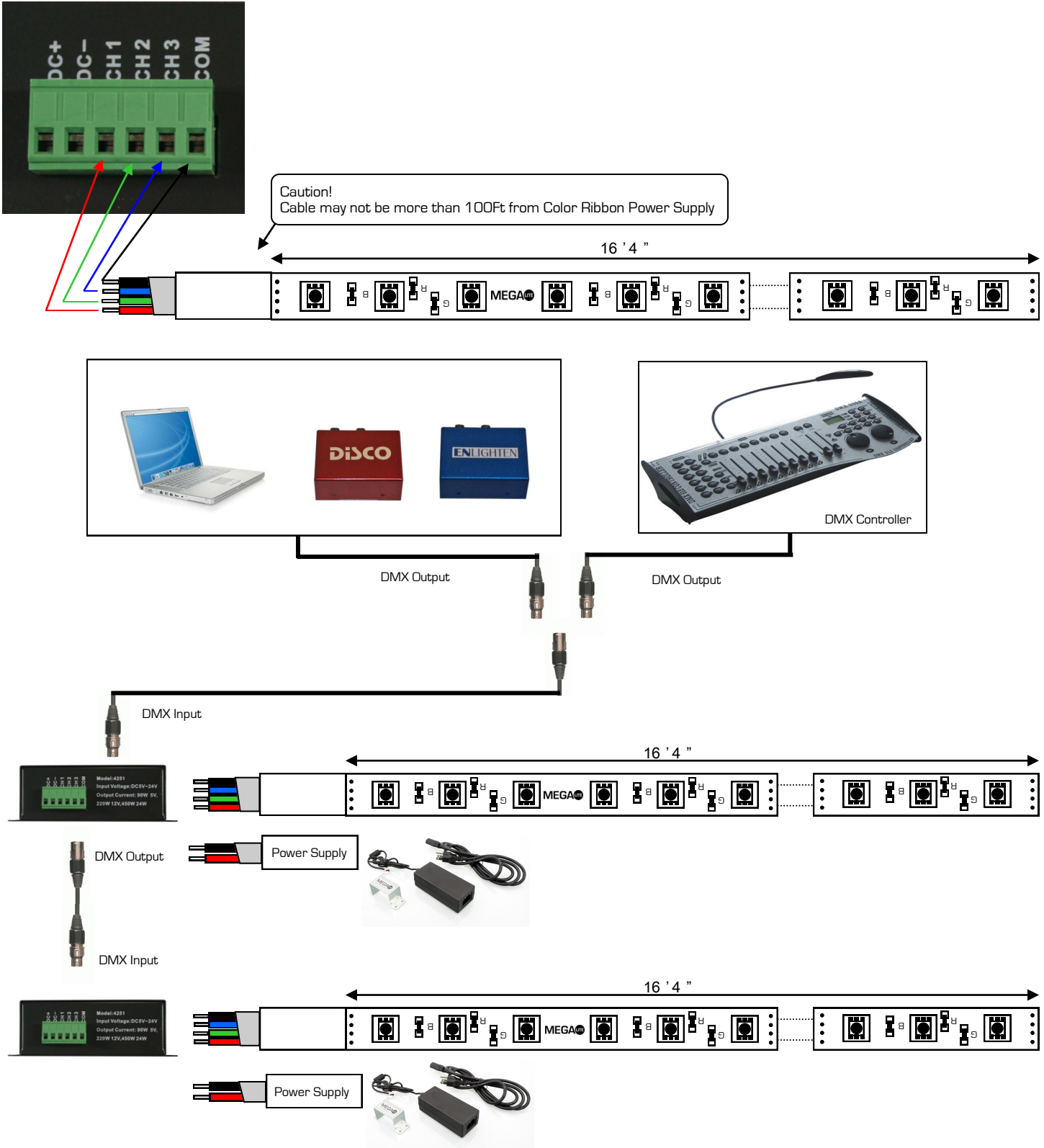

## Installing using Color Ribbon Power Supply & Ribbon Power Signal Extender

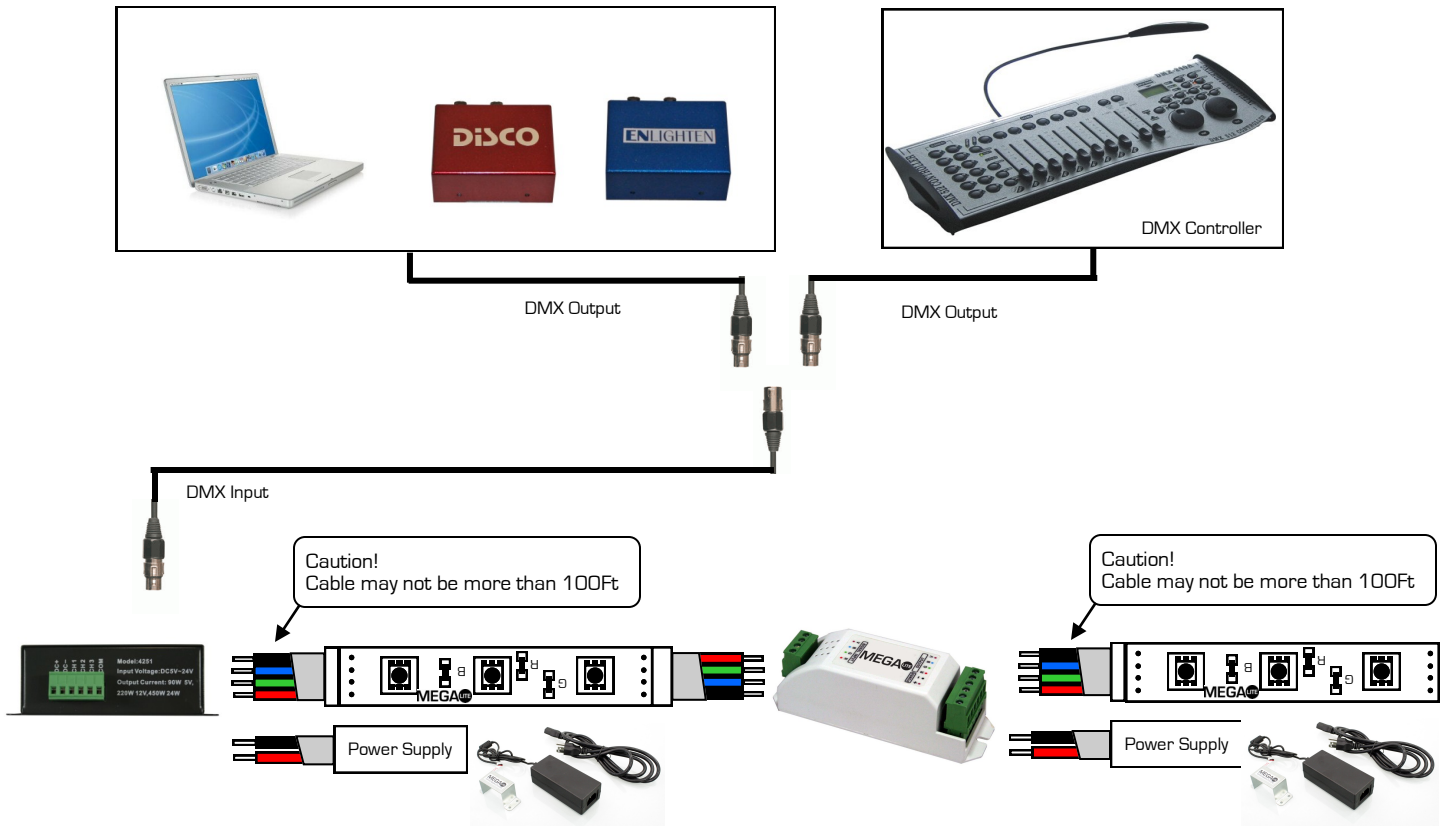

## Rigging the fixture

### Caution!

1. The installations must be carried out by an authorized dealer or trained professional.
2. Unit may cause severe injuries if you have doubts concerning the safety do not install.
3. Unit is to be 24 inches away from flammable materials (decoration material)
4. Use high quality installation equipment to hang unit.

When rigging a unit it is very important that you follow common safety procedures. Rigging requires extensive experience including but not limited to calculating working loads, material being used and periodic safety inspections. If you lack these qualifications, do not attempt the installation yourself, instead use a professional structural rigger.

Unit Ships with 10 braces per ribbon reel. These braces should be used to secure the Color Ribbon to the surface.

When rigging the unit always be secured with a secondary safety attachment. The installation location of the projector has got to be built in the way that it can hold 10 times the weight for 1 hour with out any harming. Installation should be checked at least one time a year by a skilled person.

# Main Control Menu

The control board on the fixture base is your interface to access and control all the functions on the unit. Its Dip Switch gives you a code view of the options. The following will explain each function and its options.

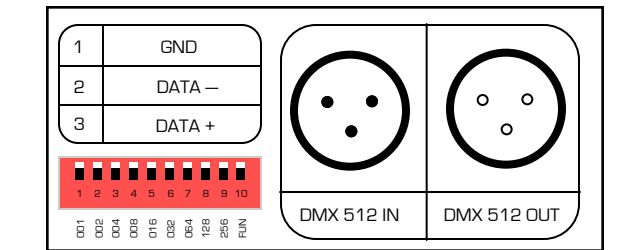

## DMX Addressing

DMX signal cable must be connected in order to respond to DMX mode.

Turn dipswitch 10 to the **OFF** position. Each dipswitch from 1 to 9 holds a numerical value located below the dipswitch. Add the numerical value to get the desired fixture start address channel. The user must assign a start address on the fixture that indicates the first channel reserved in the controller.

For example, if you wish the first unit to start on address channel 85 you will need to turn on dipswitch 1,3,5 and 7 (1+4+16+64=85)

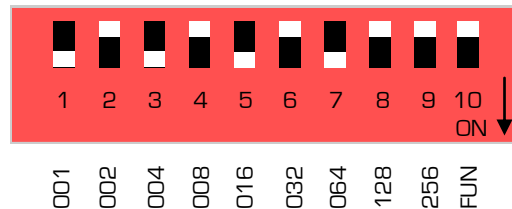

## Functions

Turn dipswitch 10 to the **ON** position. This function will turn on the functions that will allow the unit to run a preprogram function. Additionally, this unit may serve as a master unit where other units will copy it's functions. To create a master unit connect the XLR cable from the output to the input on the next unit.

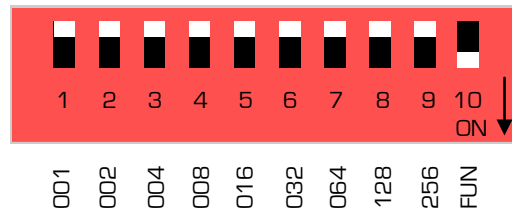

FUNCTION	1	2	3	4	5	6	7	8	9	10
RED	ON									
GREEN		ON								
BLUE			ON							
YELLOW				ON						
PURPLE					ON					
CYAN						ON				
WHITE							ON			
COLOR SNAP	SPEED 1	SPEED 2	SPEED 3	SPEED 4	SPEED 5	SPEED 6	SPEED 7	ON		
COLOR FADE	SPEED 1	SPEED 2	SPEED 3	SPEED 4	SPEED 5	SPEED 6	SPEED 7		ON	
FUNCTION	RED	GREEN	BLUE	YELLOW	PURPLE	CYAN	WHITE	COLOR S	COLOR F	ON

## Testing

For testing function do not connect DMX signal cable

Turn dipswitch 10 to the **OFF** position. This function will allow you to test the intensity of each color or to set the color ribbon to a specific color.

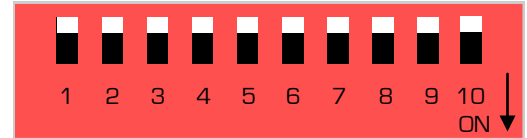

001 002 004 008 016 032 064 128 256 FUN

FUNCTION	1	2	3	4	5	6	7	8	9	10
RED	33%									
RED		33%								
RED			33%							
GREEN				33%						
GREEN					33%					
GREEN						33%				
BLUE							33%			
BLUE								33%		
BLUE									33%	
FUNCTION										OFF

## DMX Profile

### Color Ribbon DMX Profile (3 Channels)

DMX Channel	Function	Description	Value
1	Led Color	Red LED intensity	0-255
2	Led Color	Green LED intensity	0-255
3	Led Color	Blue LED intensity	0-255

## Cleaning and maintenance

**Installation Maintenance:** The operator has to make sure that the unit is operating safely and has the installations and electronics checked by an expert every 2 years.

The following points have to be considered during the inspection:

- 1) All screws used for installing the device or part of the device have to be tightly connected and must not be corroded.
- 2) There must not be any deformations on the housing, fixation and installation spots (ceiling, suspension, trussing).
- 3) The electronic power supply cables must not show any damages, material fatigue (e.g. porous cables) or sediments. Further instructions depending on the installation spot and usage have to be adhered by a skilled installer and any safety problems have to be removed.

**Disconnect from mains before starting maintenance operation!**



*Caution Danger to life!*

Electrical

We recommend a frequent cleaning of the device. Please use a moist, lint free cloth. Never use alcohol or solvents!

- 1) The plastic cover will require periodic cleaning on usage and environment. Environment with foggers will require more periodic cleaning as fog fluid tends to build up residues, reducing the light output.

**Note:** There is no serviceable parts inside the device. Maintenance and service operations are to be carried out by authorized dealers.

**Replacing the power cable:** If the power cable of this device becomes damaged, it has to be replaced by authorized dealers only in order to avoid hazards.

**Should you have further questions , please contact your dealer.**



Mega-Lite  
5718 Kenwick St  
San Antonio, TX 78238  
Ph 210-684-2600 Fax 210-855-6279  
[www.mega-lite.com](http://www.mega-lite.com) / [info@mega-lite.com](mailto:info@mega-lite.com)