



# User Manual

## Contents

Safety Information 3

Technical Information 4

Main Power & Signal Connection 5

Rigging the Fixture 7

Cleaning & Maintenance 7

Parts List 7



# MEGA LITE



Check that the unit has not been damaged during transport



Read all cautions and warnings  
prior to operation of this  
equipment

### Caution!

Read entire manual before connecting units

#### Protection Against Fire



Fire

1. Maintain a minimum of 1 foot distance from any type of flame.
2. Do Not install the unit too close to a heat source.
3. Make sure cable is properly secured away from unit heat sinks.

#### Protection Against Electrical Injury



Electrical

1. Disconnect power before LED replacement or servicing.
2. This unit must be earthed. (electronically grounded)
3. Do not expose unit to rain or moisture.

#### Protection Against Mechanical Hazards



Mechanical

1. Use safety chain when hanging unit.
2. Use quality clamps or bolts when positioning unit
3. Units are hot, Do not touch when they are on
4. Do not open unit risk of electrical shock.

# Specifications

## Part Numbers

### Fixture

4230- Dream Beam Three

## Mechanical Specifications

- Housing: Stainless Steel
- Connection: Cable mounted Cat 5 head
- Accessories: Cat 5 Splitter (included)  
 Cat 5 cable 5 meter (included)  
 MR16 nickel housing  
 8CM Frosted tube with adapter ring  
 20CM Frosted tube with adapter ring  
 120CM Frosted tube with dual adapter ring

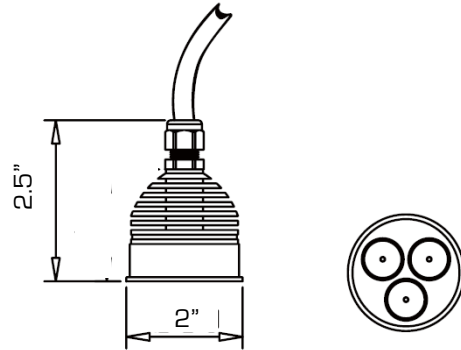

Fixture	Packaged for Shipping
Size: 2" x 2.5"	Size: 8.25"L x 3.25"W x 3.25"H
Weight: 1 lbs	Weight: 2 lbs

## LED Specifications

- LED Quantity: 3
- LED Type: 1 Red  
1 Green  
1 Blue
- LED Watts: 1 Watt each
- LED Lifetime: 50 to 100 thousand hours
- LED Angle: 30° ( ± 5° )

## Control

Dream Drive can control 12 Dream Beam Three

Dream Drive Quad can control 48 Dream Beam Three 12 per zone

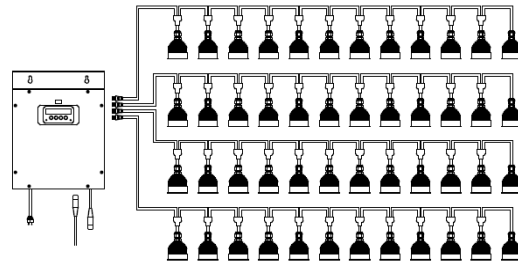
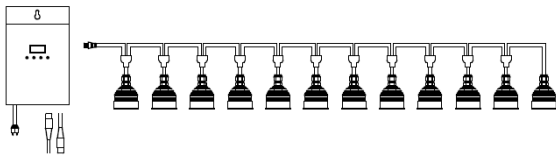

## Main Power & Signal Connection

### Caution!

1. Do not connect fixture to a dimmer system.
2. This unit must be earthed. (electronically grounded)

### Single Unit Connection Using Dream Driver

Connect Dream Beam Three connection to side of Dream Driver panel mount connection

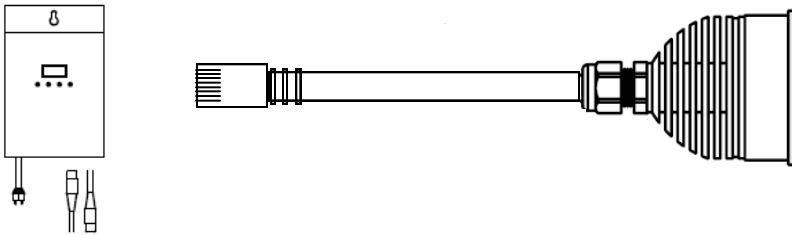

### Multiple Unit Connection Using Dream Driver

Using the Cat 5 cable (included in package)  
Connect from the output of the Dream Driver to the input marked on the Dream Beam Splitter (included in package). From the Out 1 on the Dream Driver Splitter you can connect to your Dream Beam Three. From the Out 2 you can connect the following Dream Beam Three repeating the process up to 12 times. When using a splitter you must connect 2 units in order for the splitter to work. Do not connect more than 12 units to the dream driver

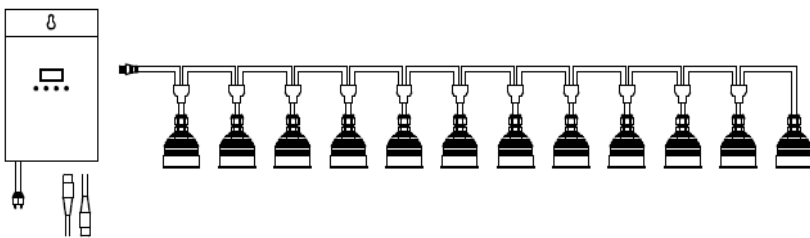

### Caution!

1. Do not connect more than 12 Dream Beam Three units to the Dream Driver
2. Cable length must not exceed 150 feet total from Dream Driver to the final unit

## Single Unit Connection Using Dream Driver Quad

Connect Dream Beam Three connection to side of Dream Driver Quad panel mount connection

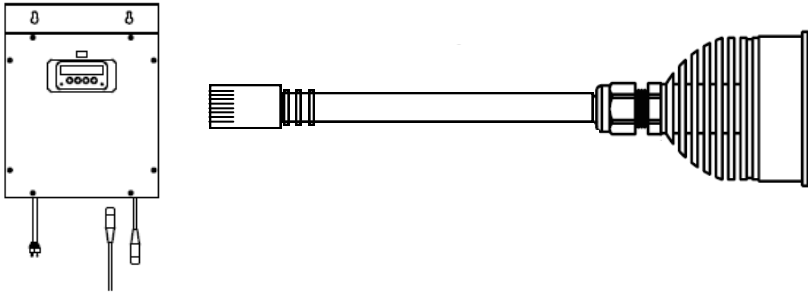

## Multiple Unit Connection Using Dream Driver Quad

Using the Cat 5 cable (included in package)

Connect from the output of the Dream Driver Quad to the input marked on the Dream Beam Splitter (included in package). From the Out 1 on the Dream Driver Splitter you can connect to your Dream Beam Three. From the Out 2 you can connect the following Dream Beam Three repeating the process up to 12 times per zone. When using a splitter you must connect 2 units in order for the splitter to work. Do not connect more than 12 units to the Dream Driver Quad per zone.

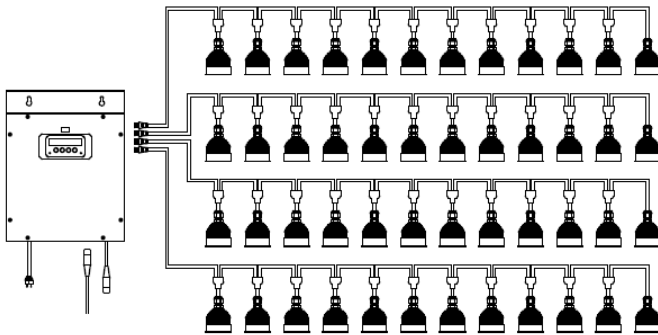

### Caution!

1. Do not connect more than 12 Dream Beam Three units per zone output
2. Cable length must not exceed 150 feet total from Dream Driver Quad to the final unit per zone

## Rigging the fixture

### Caution!

1. The installations must be carried out by an authorized dealer or trained professional.
2. Unit may cause severe injuries if you have doubts concerning the safety do not install.
3. Unit is to be 24 inches away from flammable materials (decoration material)
4. Use high quality installation equipment to hang unit.

When rigging a unit it is very important that you follow common safety procedures. Rigging requires extensive experience including but not limited to calculating working loads, material being used and periodic safety inspections. If you lack these qualifications, do not attempt the installation yourself, instead use a professional structural rigger.

When rigging the unit always be secured with a secondary safety attachment. The installation location of the projector must be built in the way that it can hold 10 times the weight for 1 hour with out any harming. Installation should be checked at least one time a year by a skilled person.

## Cleaning and maintenance

**Installation Maintenance:** The operator has to make sure that the unit is operating safely and has the installations and electronics checked by an expert every 2 years.

The following points have to be considered during the inspection:

- 1) All screws used for installing the device or part of the device have to be tightly connected and must not be corroded.
- 2) There must not be any deformations on the housing, fixation and installation spots (ceiling, suspension, trussing).
- 3) The Cat 5 cables must not show any damages, material fatigue (e.g. porous cables) or sediments. Further instructions depending on the installation spot and usage have to be adhered by a skilled installer and any safety problems have to be removed.

**Replacing the Cat 5 cable:** If the power cable of this device becomes damaged, it has to be replaced by authorized dealers only in order to avoid hazards.

## Parts List

Item Number	Description
4230-LED	LED card
4230-RLED	Red LED
4230-GLED	Green LED
4230-BLED	Blue LED
4230-5mCable	Cat 5 Cable
4230-Splitter	Dream Beam Splitter
4230-Lens	Dream Beam 30° lens kit
4240	Dream Frost 3
4241	Dream Frost 8
4242	Dream Frost 47



Mega-Lite  
5718 Kenwick St  
San Antonio, TX 78238  
Ph 210-684-2600 Fax 210-855-6279  
[www.mega-lite.com](http://www.mega-lite.com) / [info@mega-lite.com](mailto:info@mega-lite.com)