

N-E Color Par 64



USER MANUAL

Table of Contents

Safety Information.....	3
Specifications.....	4
Main Power Connection.....	5
DMX-512 Connection.....	5
Rigging the Fixture.....	9
DMX Profile.....	6
Main Control Menu.....	7
Cleaning & Maintenance.....	9
Parts List.....	9

Check that the unit has not been damaged during transport



Read all cautions and warnings
prior to operation of this
equipment

Protection Against Fire



Fire

1. Maintain a minimum of 1 foot distance from any type of flame.
3. Replace fuse only with the specified type and rating.
4. Do Not install the unit to close to a heat source.
5. Make sure cable are properly secured away from unit movement.
6. Maximum surface operating temperature 50°C.

Protection Against Fire



Electrical

1. Disconnect power before servicing.
2. For connection to main power supply proceed to page 5.
3. This unit must be earthed. (electronically grounded)
4. Do not expose unit to rain or moisture.

Protection Against Mechanical Hazards



Mechanical

1. Use safety chain when hanging unit.
2. Use quality clamps or bolts when positioning unit
3. Do not open unit while it is on, risk of electrical shock.

Technical Information

Part Numbers

Fixture

- 4032- N-E Color Par64 Polish
- 4033- N-E Color Par64 Black

Mechanical Specifications

- DMX Connectors:** 3-pin XLR connectors
- Thermal:** Maximum ambient temperature 40° C
Maximum surface temperature 60° C
- Fastening System:** Mounting Yoke

Fixture	Packaged for Shipping
Size: 16"L x 11.5"W x 17.25"H	Size: 9.25"L x 9.25"W x 19"H
Weight: 5.5 lb	Weight: 6.80 lb

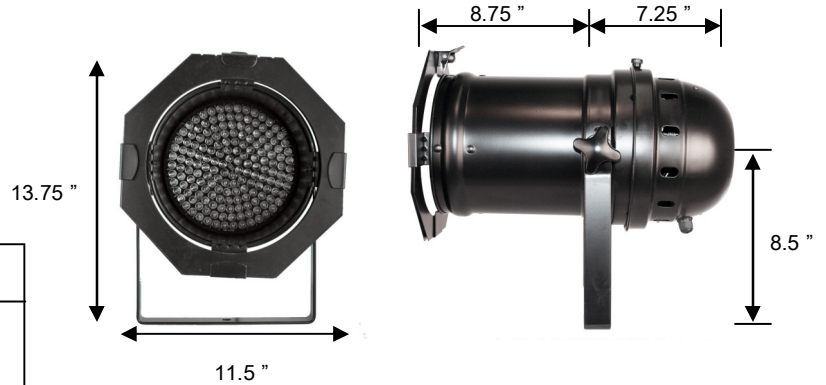

Electrical Specifications

LED Quantity: 168

- Red:** 60
- Green:** 54
- Blue:** 54

LED Diameter: 10 mm

LED Lifetime: 60,000 to 100,000 hours

LED Angle: 35° (± 5°)

Power Consumption: 115V 50/60 Hz

Ballast: Magnetic

R(60)	419	19	5	2.6	1.3	LUX
G(54)	750	35	8	4.5	2	LUX
B(54)	775	36	10	5.3	2.5	LUX
RGB(168)	1438	69	24	11.5	5.6	LUX

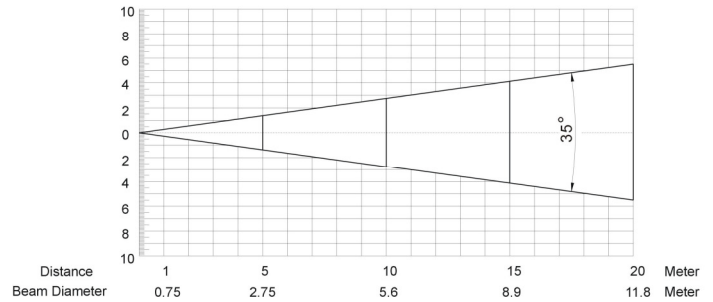

Control & Programming

Protocol: DMX 512

DMX Channels: 4 Channels

Control options: Auto Via dip switch

Operating mode: Master/Slave, Stand alone

Main Power Connection

Caution!

1. Do not connect fixture to a dimmer system.
2. This unit has Auto switching power supply. It will respond to 110V or 220V automatically
3. This unit must be earthed. (electronically grounded)
4. Replace fuse only with the specified type and rating.

The occupation of the connection-cable is as follows:

110V Connection

Cable (USA)	Cable (EU)	Pin	Connection
Black	Brown	Live	L
White	Light Blue	Neutral	N
Green	Yellow/Green	Ground	

DMX-512 Connection

The fixture is equipped with 3 pin XLR Sockets for DMX input and output. The sockets are wired in parallel. Only use a shielded twisted pair cable designed for RS-485 and 3 pin XLR plugs and connectors in order to connect the controller with the fixture or the fixture with another.

DMX—input

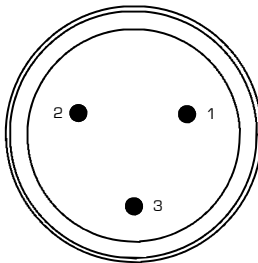

DMX—output

1. Shield
2. Signal (-)
3. Signal (+)

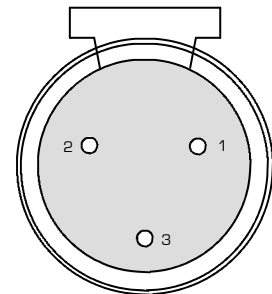

Caution!

At the last fixture the DMX signal needs to be terminated with a terminator. Solder a 120 Ohm resistor between the (-) and the (+) signal into a 3 pin XLR plug and plug it in to the last fixture on the signal run. Pre-manufactured terminator plugs are available for purchase from your Mega-Lite dealer (HOS-DMXT).

Rigging the fixture

Caution!

1. The installations must be carried out by an authorized dealer or trained professional.
2. Unit may cause severe injuries if you have doubts concerning the safety do not install.
3. Unit is to be 24 inches away from flammable materials (decoration material)
4. Use high quality installation equipment to hang unit.

When rigging a unit it is very important that you follow common safety procedures. Rigging requires extensive experience including but not limited to calculating working loads, material being used and periodic safety inspections. If you lack these qualifications, do not attempt the installation yourself, instead use a professional structural rigger.

When rigging the unit always be secured with a secondary safety attachment. The installation location of the projector has got to be built in the way that it can hold 10 times the weight for 1 hour with out any harming. Installation should be checked at least one time a year by a skilled person.

DMX Profile

N-E Color Par 64

DMX Chanel	Function	Description	Value
1	Dimmer	Dimmer	0-152
		Strobe (slow to fast)	153-242
		Dimmer Full On	243-255
2	LED Color	Red LED intensity	0-255
3	LED Color	Green LED Intensity	0-255
4	LED Color	Blue LED Intensity	0-255

Main Control Menu

The control board on the fixture base is your interface to access and control all the functions on the unit. Its dipswitch interface gives you a code view of the options. The following will explain each function and its options.

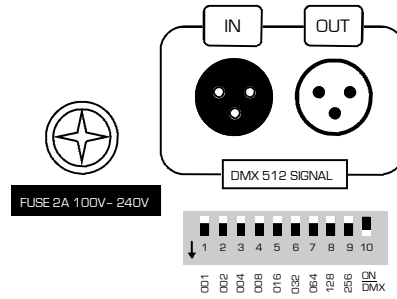

DMX Addressing

Turn dipswitch 10 to the **Down** position. Each dipswitch from 1 to 9 holds a numerical value located below the dipswitch. Add the numerical value to get the desired fixture start address channel. The user must assign a start address on the fixture that indicates the first channel reserved in the controller.

For example, if you wish the first unit to start on address channel 85 you will need to turn on dipswitch 1,3,5 and 7 (1+4+16+64=85)



Functions

Turn dipswitch 10 to the **UP** position. This function will turn on the functions that will allow the unit to run a preprogram function. Additionally, this unit may serve as a master unit where other units will copy it's functions. To create a master unit connect the XLR cable from the output to the input on the next unit. And address the next unit as fixture 1.

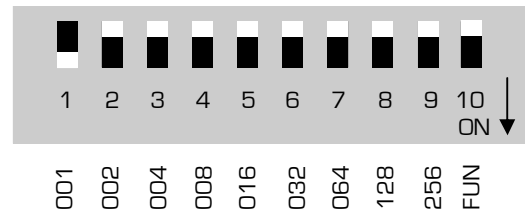

FUNCTION	1	2	3	4	5	6	7	8	9	10
RED	ON 1/2	ON 1/2								
GREEN			ON 1/2	ON 1/2						
BLUE					ON 1/2	ON 1/2				
STROBE	SLOW	FAST							ON	
COLOR FADE			SLOW	FAST					ON	
COLOR SNAP					FASTEST	FAST	MED	SLOW	ON	
DMX	1	2	4	8	16	32	64	128	256	ON

Cleaning and maintenance

Installation Maintenance: The operator has to make sure that the unit is operating safely and has the installations and electronics checked by an expert every 2 years.

The following points have to be considered during the inspection:

- 1) All screws used for installing the device or part of the device have to be tightly connected and must not be corroded.
- 2) There must not be any deformations on the housing, fixation and installation spots (ceiling, suspension, trussing).
- 3) The electronic power supply cables must not show any damages, material fatigue (e.g. porous cables) or sediments. Further instructions depending on the installation spot and usage have to be adhered by a skilled installer and any safety problems have to be removed.

Disconnect from mains before starting maintenance operation!



Caution Danger to life!

Electrical

We recommend a frequent cleaning of the device. Please use a moist, lint free cloth. Never use alcohol or solvents!

- 1) The plastic cover will require periodic cleaning on usage and environment. Environment with foggers will require more periodic cleaning as fog fluid tends to build up residues, reducing the light output.

Note: There is no serviceable parts inside the device except for the LED's. Maintenance and service operations are to be carried out by authorized dealers.

Replacing the fuse: Only replace the fuse with the same type and rating.

Replacing the power cable: If the power cable of this device becomes damaged, it has to be replaced by authorized dealers only in order to avoid hazards.

Should you have further questions , please contact your dealer.

Parts List

4032-mwk	Knobs
4032-sh	Spring lid holder set
4030-ledmod	LED module
4032-mainc	Main PCB card
4000-dmx	XLR Connections
4000-fh	Fuse Holder
4030-ps	Power Supply



Mega-Lite
5718 Kenwick St
San Antonio, TX 78238
Ph 210-684-2600 Fax 210-855-6279
www.mega-lite.com / info@mega-lite.com